

# L85SA-R-AC-50

50cd red aeronautical obstruction light

**A new generation of LED low intensity aeronautical obstruction lights to meet the demanding requirements of offshore environmental conditions. The design is based on low power long life LED technology and use of stainless steel.**



### Key features

- Reliable low intensity aeronautical obstruction light
- Low cost of ownership
- Low power consumption
- Serviceable unit, parts are interchangeable
- Compact design
- Impact resistant dome and stainless steel 316 body
- Spacious, easy to open cable connection compartment

### Performance characteristics

- Steady burning; red
- Intensity: 50cd
- Horizontal coverage: 360°
- Vertical beam profile: Visible from any point above the horizon
- Colour chromaticity within the boundaries as specified by ICAO
- Light source: LED (100,000 hours average life)

### Electrical characteristics

- Operating voltage: 100-254Vac; 50-60 Hz
- Power consumption: 8W (9VA)
- Connection details: M4; two M25x1.5 cable entries
- Earth connection: internal M4 and external M6

### Physical characteristics

- Dimensions (L x W x H): 161 x 161 x 111mm
- Weight: 3.6kg
- Design degree of protection: IP66
- Operating temperature range: -40°C to +55°C

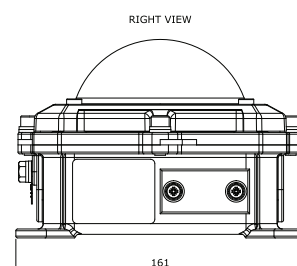
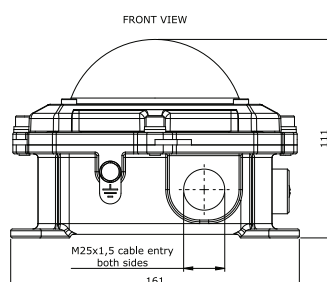
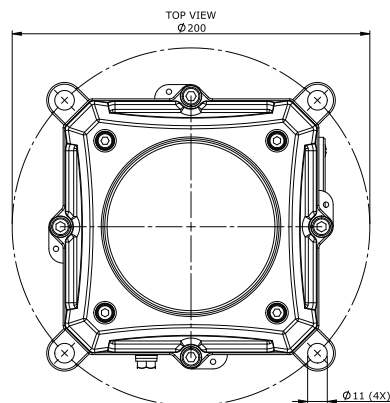

Orga BV  
Strickledeweg 13  
3125 AT SCHIEDAM  
The Netherlands

P.O. Box 3046  
3101 EA SCHIEDAM  
The Netherlands

T +31 (0)10 208 5555  
F +31 (0)10 437 8445  
info@orga.nl  
www.orga.nl